

BACK PRESSURE REGULATOR MADE OF STAINLESS STEEL THROUGHOUT

D3000

Description	The back pressure regulator protects compressed air devices from excessive pressure. If the pressure setpoint is exceeded, overpressure is vented into the atmosphere until the setpoint is reached again. It is recommended to choose a pressure range as low as possible. compressed air, gases or liquids
Media	compressed air, gases or liquids
System pressure	see chart, max. 70 bar
Adjustment	by adjusting screw at D3000-01 to -A6, with locknut by T-handle at D3000-06 to -16, with locknut
Gauge port	for inlet pressure, G $\frac{1}{8}$ on both sides, all others G $\frac{1}{4}$, screw plugs supplied
Mounting position	any
Temperature range	0 °C to 80 °C / 32 °C to 176 °F for FKM or EPDM 0 °C to 130 °C / 32 °C to 266 °F for high temperature version for appropriately conditioned compressed air down to -20 °C / -4 °F or low temperature version down to -40 °C / -40 °F
Material	Body: stainless steel 316L, material no 1.4404 O-rings: FKM, optionally NBR/Buna-N or EPDM Diaphragm: NBR/Buna-N with PTFE coating, optionally stainless steel Inner valve: stainless steel 316L, material no 1.4404

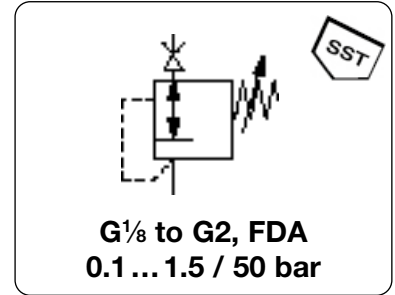

Dimensions			Regul. system	Exhaust	Over-	Connection	Adjustment	Order
A	B	C	D: Diaphragm	rate	pressure	thread	range	number
mm	mm	mm	P: Piston	l/min*1	max. bar	G	bar	

Back pressure regulator			overpressure max. 30 / 65 bar, PTFE diaphragm and FKM o-ring		D3000			
40	83	13	M	400	30	G $\frac{1}{8}$	0,1 ... 1,5 0,2 ... 3,0 0,5 ... 8,0 1,0 ... 15	D3000-01AT D3000-01BT D3000-01DT D3000-01ET
40	83	13	M	400	30	G $\frac{1}{4}$	0,1 ... 1,5 0,2 ... 3,0 0,5 ... 8,0 1,0 ... 15	D3000-A2AT D3000-A2BT D3000-A2DT D3000-A2ET
109	140	17	M	2300	22,5	G $\frac{1}{4}$	0,1 ... 1,5 0,2 ... 3,0 0,5 ... 8,0 1,0 ... 15	D3000-02AT D3000-02BT D3000-02DT D3000-02ET
109	153	17	K	2300	70		2,0 ... 30 3,0 ... 50	D3000-02FT D3000-02GT
109	140	17	M	2300	22,5	G $\frac{3}{8}$	0,1 ... 1,5 0,2 ... 3,0 0,5 ... 8,0 1,0 ... 15	D3000-03AT D3000-03BT D3000-03DT D3000-03ET
109	153	17	K	2300	70		2,0 ... 30 3,0 ... 50	D3000-03FT D3000-03GT
109	140	17	M	2300	22,5	G $\frac{1}{2}$	0,1 ... 1,5 0,2 ... 3,0 0,5 ... 8,0 1,0 ... 15	D3000-04AT D3000-04BT D3000-04DT D3000-04ET
109	153	17	K	2300	70		2,0 ... 30 3,0 ... 50	D3000-04FT D3000-04GT

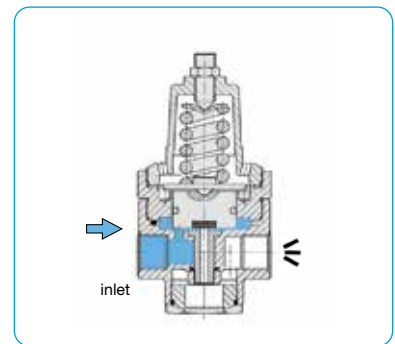
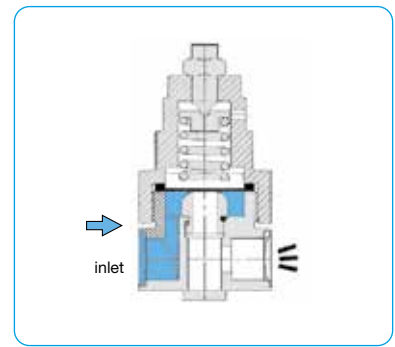

Accessories, see next pages

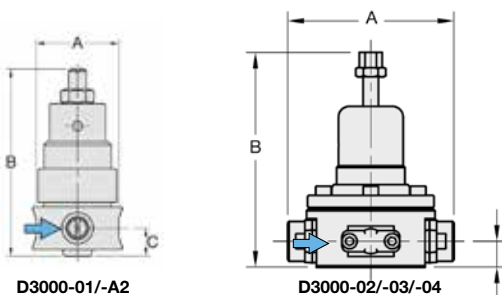

*1 at 7 bar overpressure and open outlet

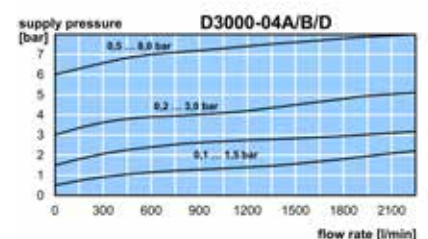

Gauges: see chapter for measuring devices

PDF CAD
www.aircom.net

Order example:
D3000-02AT

BACK PRESSURE REGULATOR MADE OF STAINLESS STEEL THROUGHOUT

D3000

Description	The back pressure regulator protects compressed air devices from excessive pressure. If the pressure setpoint is exceeded, overpressure is vented into the atmosphere until the setpoint is reached again. It is recommended to choose a pressure range as low as possible. compressed air, gases or liquids
Media	compressed air, gases or liquids
System pressure	see chart, max. 70 bar
Adjustment	by adjusting screw at D3000-01 to -A6, with locknut by T-handle at D3000-06 to -16, with locknut
Gauge port	for inlet pressure, G $\frac{1}{4}$ on both sides, screw plugs supplied
Mounting position	any
Temperature range	0 °C to 80 °C / 32 °C to 176 °F for FKM or EPDM 0 °C to 130 °C / 32 °C to 266 °F for high temperature version for appropriately conditioned compressed air down to -20 °C / -4 °F or low temperature version down to -40 °C / -40 °F
Material	Body: stainless steel 316L, material no 1.4404 O-rings: FKM, optionally EPDM Diaphragm: NBR/Buna-N with PTFE coating, optionally stainless steel Inner valve: stainless steel 316L, material no 1.4404

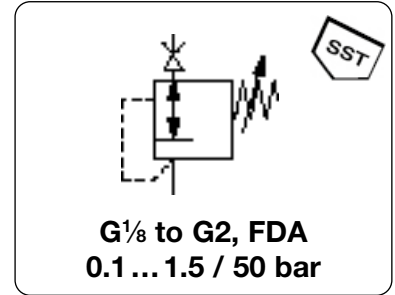

Dimensions			Regul. system	Exhaust	Over-	Connection	Adjustment	Order
A	B	C	D: Diaphragm	rate	pressure	thread	range	number
mm	mm	mm	P: Piston	l/min*1	max. bar	G	bar	

Back pressure regulator				overpressure max. 30 / 65 bar, PTFE diaphragm and FKM o-ring	D3000			
165	246	21	M	8000	30	G $\frac{3}{4}$	0,1 ... 1,5	D3000-06AT
							0,2 ... 3,0	D3000-06BT
							0,5 ... 8,0	D3000-06DT
							1,0 ... 15	D3000-06ET
165	270	21	K	8000	65		2,0 ... 30	D3000-06FT
							3,0 ... 50	D3000-06GT
165	246	21	M	8000	30	G1	0,1 ... 1,5	D3000-08AT
							0,2 ... 3,0	D3000-08BT
							0,5 ... 8,0	D3000-08DT
							1,0 ... 15	D3000-08ET
165	270	21	K	8000	65		2,0 ... 30	D3000-08FT
							3,0 ... 50	D3000-08GT
269	246	21	M	8000	30	G1 $\frac{1}{4}$	0,1 ... 1,5	D3000-10AT
							0,2 ... 3,0	D3000-10BT
							0,5 ... 8,0	D3000-10DT
							1,0 ... 15	D3000-10ET
269	270	21	K	8000	65		2,0 ... 30	D3000-10FT
							3,0 ... 50	D3000-10GT
269	246	21	M	8000	30	G1 $\frac{1}{2}$	0,1 ... 1,5	D3000-1AAT
							0,2 ... 3,0	D3000-1ABT
							0,5 ... 8,0	D3000-1ADT
							1,0 ... 15	D3000-1AET
269	270	21	K	8000	65		2,0 ... 30	D3000-1AFT
							3,0 ... 50	D3000-1AGT

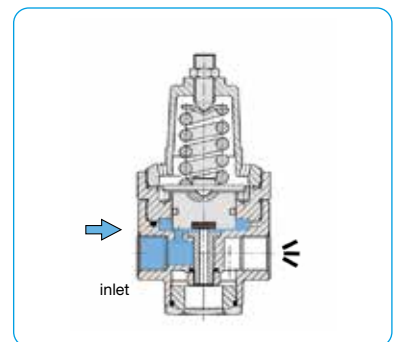
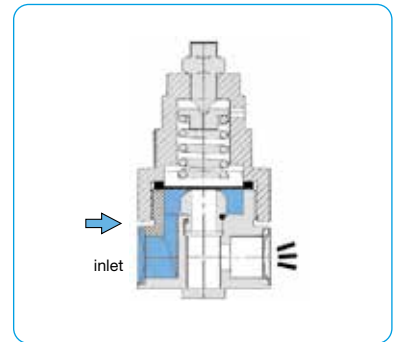

SST
SST
15

Accessories, see next pages

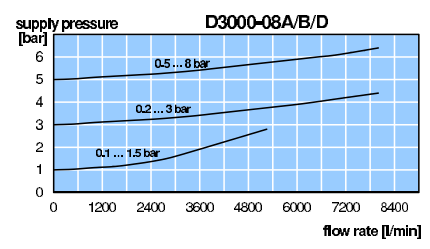
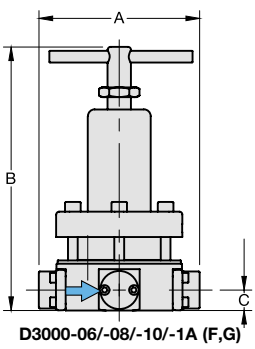
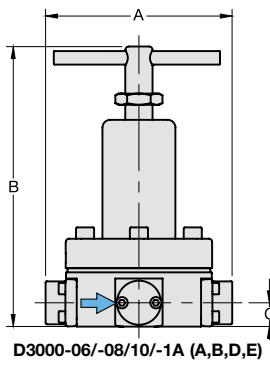

*1 at 7 bar overpressure and open outlet

BACK PRESSURE REGULATOR MADE OF STAINLESS STEEL THROUGHOUT

D3000

Description	The back pressure regulator protects compressed air devices from excessive pressure. If the pressure setpoint is exceeded, overpressure is vented into the atmosphere until the setpoint is reached again. It is recommended to choose a pressure range as low as possible. compressed air, gases or liquids
Media	compressed air, gases or liquids
System pressure	see chart, max. 70 bar
Adjustment	by adjusting screw at D3000-01 to -A6, with locknut by T-handle at D3000-06 to -16, with locknut
Gauge port	for inlet pressure, G $\frac{1}{4}$ on both sides, screw plugs supplied
Mounting position	any
Temperature range	0 °C to 80 °C / 32 °C to 176 °F for FKM or EPDM 0 °C to 130 °C / 32 °C to 266 °F for high temperature version for appropriately conditioned compressed air down to -20 °C / -4 °F or low temperature version down to -40 °C / -40 °F
Material	Body: stainless steel 316L, material no 1.4404 O-rings: FKM, optionally EPDM Diaphragm: NBR/Buna-N with PTFE coating, optionally stainless steel Inner valve: stainless steel 316L, material no 1.4404

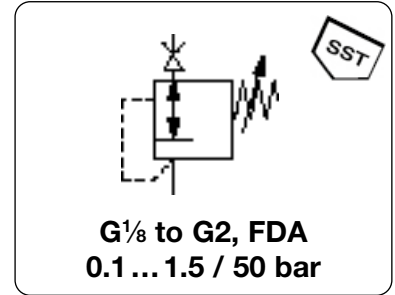

Dimensions			Regul. system	Exhaust	Over-	Connection	Adjustment	Order
A	B	C	D: Diaphragm	rate	pressure	thread	range	number
mm	mm	mm	P: Piston	l/min*1	max. bar	G	bar	

Back pressure regulator			overpressure max. 30 / 65 bar, PTFE diaphragm and FKM o-ring		D3000			
171	376	128	M	25 000	30	G $\frac{1}{2}$	0.1 ... 1.5	D3000-12AT
							0.2 ... 3.0	D3000-12BT
							0.5 ... 8.0	D3000-12DT
							1.0 ... 15	D3000-12ET
171	387	128	P	25 000	65		2.0 ... 30	D3000-12FT
							3.0 ... 50	D3000-12GT
171	376	128	M	25 000	30	G2	0.1 ... 1.5	D3000-16AT
							0.2 ... 3.0	D3000-16BT
							0.5 ... 8.0	D3000-16DT
							1.0 ... 15	D3000-16ET
171	387	128	P	25 000	65		2.0 ... 30	D3000-16FT
							3.0 ... 50	D3000-16GT



D3000-12/-16

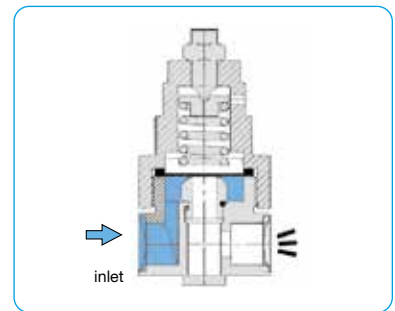

with diaphragm

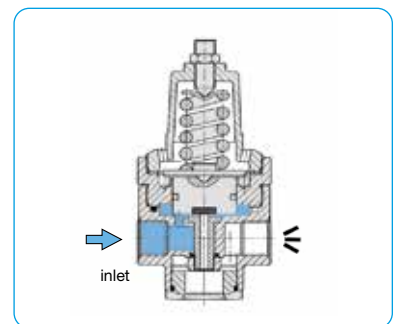

with piston

Accessories, see next page

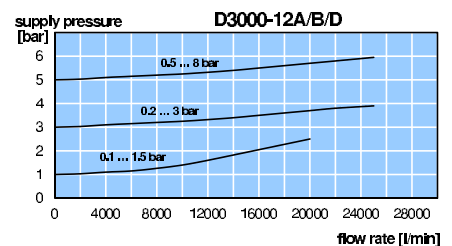
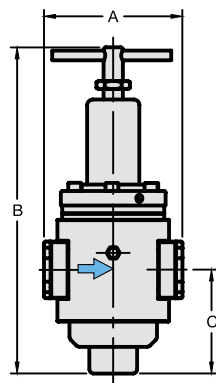

*1 at 7 bar overpressure and open outlet

PDF CAD
www.aircom.net

Order example:
D3000-12AT

BACK PRESSURE REGULATOR MADE OF STAINLESS STEEL THROUGHOUT

D3000

Description	The back pressure regulator protects compressed air devices from excessive pressure. If the pressure setpoint is exceeded, overpressure is vented into the atmosphere until the setpoint is reached again. It is recommended to choose a pressure range as low as possible.
Media	compressed air, gases or liquids
System pressure	see chart, max. 70 bar
Adjustment	by adjusting screw at D3000-01 to -A6, with locknut by T-handle at D3000-06 to -16, with locknut
Gauge port	for inlet pressure, G $\frac{1}{4}$ on both sides, screw plugs supplied
Mounting position	any
Temperature range	0 °C to 80 °C / 32 °C to 176 °F for FKM or EPDM 0 °C to 130 °C / 32 °C to 266 °F for high temperature version for appropriately conditioned compressed air down to -20 °C / -4 °F or low temperature version down to -40°C / -40 °F
Material	Body: stainless steel 316L, material no 1.4404 O-rings: FKM, optionally EPDM Diaphragm: NBR/Buna-N with PTFE coating, optionally stainless steel Inner valve: stainless steel 316L, material no 1.4404

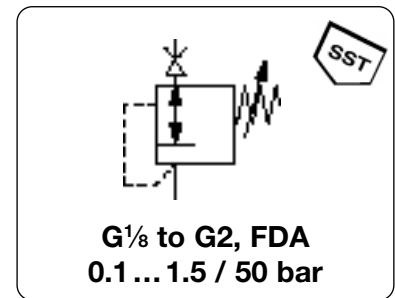

Dimensions			Regul. system	Exhaust	Over-	Connection	Adjustment	Order
A	B	C	D: Diaphragm	rate	pressure	thread	range	number
mm	mm	mm	P: Piston	l/min*1	max. bar	G	bar	

Special options, add the appropriate letter

pilot operated		D3000- J
NPT	connection thread	D3000- N
down to -40 °C/ -40°F	low temperature version	D3000- X51
up to 130 °C/266 °F	high temperature version	D3000- X54
FKM -o-ring	for piston regulator or PTFE diaphragm	D3000- T
EPDM-o-ring		D3000- TE
EPDM-o-ring	FDA-approval	D3000- TD
SST diaphragm	FKM -o-ring	D3000- S
	NBR -o-ring	D3000- SB
	EPDM-o-ring	D3000- SE
	EPDM-o-ring, FDA-approval	D3000- SD
ammonia	NH ₃	D3000- 02
carbon dioxide	CO ₂	D3000- 03
argon	Ar	D3000- 05
nitrogen	N ₂	D3000- 07
helium	He	D3000- 09
hydrogen	H ₂	D3000- 11
methane	CH ₄	D3000- 13
natural gas *3		D3000- 14
oxygen	O ₂	D3000- 15
propane	C ₃ H ₈	D3000- 16
nitrous oxide	N ₂ O	D3000- 17
water	H ₂ O	D3000- W
flange connection	see end of the chapter / flanges	D3000- F.

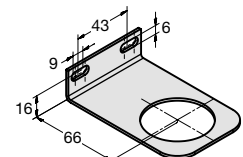

BW45-03S

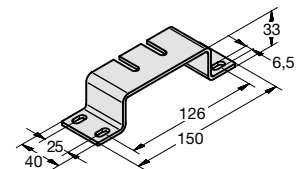

BW00-59S

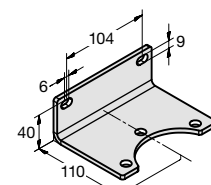

BW00-62S



Accessories, enclosed

pressure gauge	Ø 50 mm, 0...*2 bar, G $\frac{1}{4}$	for G $\frac{1}{4}$ to G $\frac{1}{2}$	MS5002-..*2
	Ø 63 mm, 0...*2 bar, G $\frac{1}{4}$	for G $\frac{3}{4}$ to G2	MS6302-..*2
mounting bracket		for G $\frac{1}{4}$ and G $\frac{1}{2}$	BW45-03S
mounting nut			M45x1,5S
mounting bracket		for G $\frac{3}{4}$ to G1 $\frac{1}{2}$ (1A)	BW00-59S
		for G1 $\frac{1}{2}$ (12) and G2	BW00-62S

*1 at 7 bar overpressure and open outlet

*2 02 = 0...2.5 bar, 04 = 0...4 bar, 06 = 0...6 bar, 10 = 0...10 bar, 16 = 0...16 bar, 60 = 0...60 bar

*3 without DVGW-approval

Gauges: see chapter for measuring devices

PDF CAD
www.aircom.net



Order example:
MS5002-02